

DETECT-A-FIRE®

Detection and Release Devices



12.01.8

FEATURES

- *Repeatable - resets itself, nothing to replace, testable*
- *Rugged - withstands shock and vibration*
- *Versatile - offers various temperature settings*
- *Durable - long lasting stainless steel shell*
- *Economical - wide spacing, reduces installation cost*
- *Factory set and the internal contact area is hermetically sealed in stainless steel*

APPLICATIONS

- *Protection of schools, factories, offices, libraries, etc.*
- *Paint spray booths*
- *Range hoods*

DESCRIPTION

DETECT-A-FIRE units are the "heart" of many Fire Protection Systems. These highly reliable devices have been a standard of the industry for over 45 years. Many thousands of these units are now in use controlling the release of extinguishants such as clean agents, CO₂, water, or dry chemicals. In some systems the device is used as an ALARM device, to sense overheat or fire, and alert personnel. In other systems, it is used as a RELEASE device, to sense fire and actuate fire attack systems.

DETECT-A-FIRE units have met with wide acceptance because they are designed with RATE COMPENSATION. This provides a unique advantage over both fixed temperature and rate-of-rise types of detectors because only the DETECT-A-FIRE unit accurately senses the surrounding air temperature regardless of the fire growth rate. At precisely the predetermined danger point, the system is activated.

Fixed temperature detectors must be completely heated to alarm temperature and therefore a disastrous lag in time may occur with a fast rate fire. Rate-of-rise devices, on the other hand, are triggered by the rate of increase in ambient temperature and are subject to false alarms caused by harmless, transient thermal gradients such as the rush of warm air from process ovens.



The secret of the unit's sensitivity is in the design (Figure 1). The outer shell is made of a rapidly expanding alloy which closely follows changes in surrounding air temperature. The inner struts are made of a lower expanding alloy. Designed to resist thermal energy absorption and sealed inside the shell, the struts follow temperature changes more slowly.

A slow rate fire (Figure 2) will heat the shell and struts together. At the "set point," the unit will trigger, actuating the alarm or releasing the extinguishant.

A transient rush of warm air up to 40° F/min. may expand the shell, but not enough to trigger the unit. By ignoring transient warm air excursions, the DETECT-A-FIRE unit virtually eliminates false alarms prevalent with rate-of-rise devices.

If a fast rate fire (Figure 3) starts, the shell will expand rapidly. The struts will close, actuating the alarm or releasing the agent. The faster the fire rate of growth, the sooner the DETECT-A-FIRE unit will react.

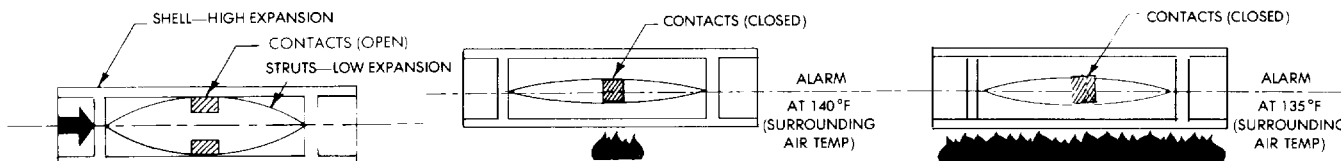

FIGURE 1: READY

FIGURE 2: SLOW FIRE

FIGURE 3: FAST FIRE

SPECIFICATIONS

HORIZONTAL DETECT-A-FIRE-UNITS

Horizontal detectors are designed for locations where appearance is a factor. The attractive, functional design lends physical protection of the unit while making it suitable for commercial, industrial, mercantile and public buildings, institutions and ships in non-hazardous locations (those classified as "ordinary" under the National Electric Code). Flush mounted units are designed to fit standard 4" octagonal electrical boxes and surface mounting units are designed to mount directly on ceilings or on 4" electrical junction boxes. Canadian Electrical Codes requires mounting only to an electrical junction box.

VERTICAL DETECT-A-FIRE-UNITS

Vertical detectors are designed for use in both "ordinary" or "hazardous" locations. For "ordinary" use, they may be mounted to any approved junction box with 7/8" diameter opening by using 1/2-14 NPT mounting nuts. The device may be wired in or out of conduit, depending on local preference and codes. Four leadwires are provided on normally open vertical units (that close on temperature rise), per UL requirement, to facilitate supervision of system wiring. Instruments are Underwriters Laboratory and Underwriters Laboratory of Canada listed and Factory Mutual approved for hazardous locations, when mounted in a suitable fitting.

MOUNTING

DETECT-A-FIRE units are not position sensitive. Horizontal and vertical detectors refer to the most common mounting configuration for that unit. However, each type can be mounted either horizontally or vertically depending on the application and installation requirements.

HAZARDOUS LOCATIONS	DETECTOR TYPE	FITTING REQUIRED FOR UL & ULC LISTINGS AND FM APPROVAL
Class I, Groups A, B, C and D; Class II, Groups E, F and G	12-X27120-022 12-X27121-020 12-X28020-003 12-X28021-005	Mount detector to a suitable listed fitting in accordance with National Electric Code and/or local authority having jurisdiction.
Class I, Groups B, C and D; Class II, Groups E, F and G	12-X27120-000 12-X27121-000 12-X28021-000	

NOTE: Only units with stainless steel shell and head are approved for Class I, Group A locations.

NOTE A: Spacings shown are distances between units on smooth ceilings, the distances from partitions or walls would be half that shown. Authority having LOCAL jurisdiction should be consulted before installation.

NOTE B: Temperature preset at factory only. Special settings available upon request. Consult factory or Fenwal Representative for additional information.

NOTE C: In applications where corrosion is suspect, care should be taken to protect the DETECT-A-FIRE unit to realize optimum performance and maximum life. Consult factory for suggestions.

NOTE D: Up to 375°F-#18 AWG Teflon insulated wire used on units.
Above 375°F-#16 AWG TGGT insulated wire used on units.

NOTE E: Per UL521 requirements - low temperature exposure test is -22°F (-30°C)

Specifications subject to change without notice.

UL of Canada labeling available upon request.

Although incandescent lamps are considered resistive, their inrush current is 10-15 times their steady current. Do not exceed ratings.

HORIZONTAL DETECT-A-FIRE-UNITS



Flush Mounting Unit for Concealed Wiring

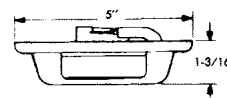
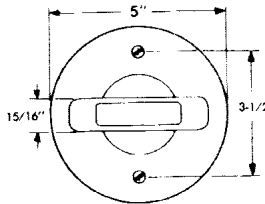

12-X27020-000
12-X27021-000



Surface Mounting Unit for Exposed Wiring

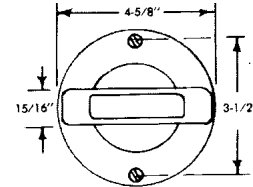

12-X27020-001
12-X27021-001

MODEL NO.	CONTRACT OPERATION ON TEMPERATURE RISE	APPROX. WEIGHT PER UNIT	ELECTRICAL RATING (RESISTIVE ONLY)
12-X27020-000 12-X27020-001	Opens (325°F Max)	10 oz	5.0 Amps 125 VAC 0.5 Amps 125 VDC
12-X27021-000 12-X27021-001	Closes (325°F (Max))	10 oz	5.0 Amps 125 VAC 0.5 Amps 125 VDC 2.0 Amps 24 VDC 1.0 Amps 48 VDC

CONSTRUCTION

Stainless steel shell sensing element. Cold rolled steel mounting facility. Off-White finish.

TEMPERATURE RATING

(Suggested setting a minimum of 100°F above ambient)

°F SETTING	°F TOLERANCE	SPACINGS (in feet) See NOTE A			COLOR CODING
		UL	ULC	FM	
140	+ 7/-8	50	50	25	Black
160	+ 7/-8	25	25	25	Black
190	+ 7/-8	50	50	25	White
225	+ 7/-8	25	50	25	White
275	± 10	25	50	25	Blue
325	± 10	50	50	25	Red
360	± 10	25	50	25	Red
450	± 15	25	50	25	Green
600	± 20	N/A	50	25	Orange
725	± 25	N/A	50	25	Orange

VERTICAL DETECT-A-FIRE-UNITS

For Concealed and Exposed Wiring
(Hexagonal Head)

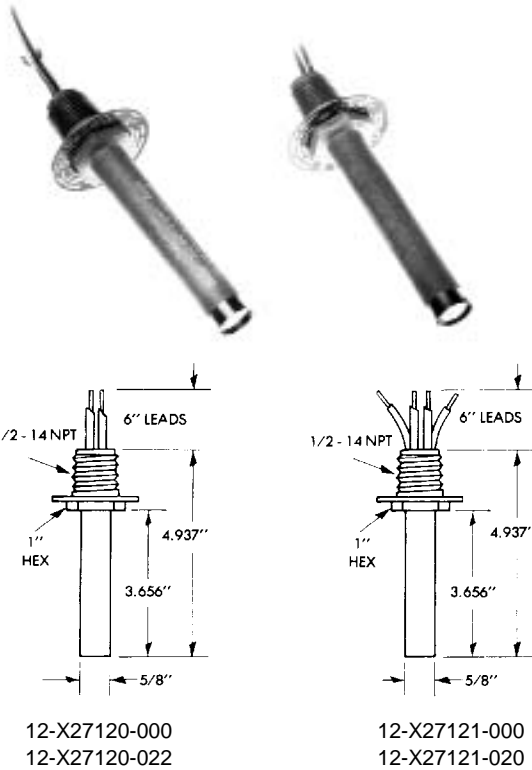

VERTICAL DETECT-A-FIRE-UNITS

For Concealed and Exposed Wiring
(Coupling Head)

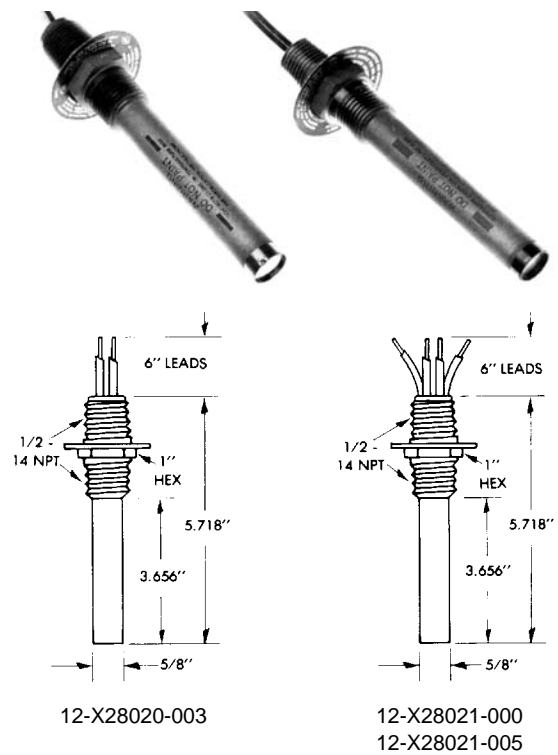

MODEL NUMBER	MOUNTING HEAD MATERIAL	SHELL MATERIAL	CONTACT OPERATION ON TEMPERATURE RISE	ELECTRICAL RATING (RESISTIVE ONLY)	APPROX. WEIGHT PER UNIT
12-X27120-000 12X27120-022	Brass Type 300 Stainless Steel	Type 300 Stainless Steel	Opens (450 °F Max)	5.0 Amps 125 VAC 0.5 Amps 125 VDC	5 oz.
12-X27121-000 12-X27121-020	Brass Type 300 Stainless Steel		Closes	5.0 Amps 125 VAC 0.5 Amps 125 VDC 2.0 Amps 24 VDC 1.0 Amps 48 VDC	5 oz.
12X28020-003	Type 300 Stainless Steel		Opens (450 °F Max.)	5.0 Amps 125 VAC 0.5 Amps 125 VDC	5 oz.
12-X28021-000 12-X28021-005	Brass Type 300 Stainless Steel		Closes	5.0 Amps 125 VAC 0.5 Amps 125 VDC 2.0 Amps 24 VDC 1.0 Amps 48 VDC	5 oz.

X

STOCKED MODELS AND TEMPERATURE SETTINGS

(Suggested setting a minimum of 100 °F above ambient)

Indicates a stock unit

MODEL	TEMPERATURE SETTING (°F)									
	140	160	190	225	275	325	360	450	600	725
12-X27020-000	X		X							
12-X27020-001	X									
12-X27021-000	X		X							
12-X27021-001	X		X							
12-X27120-000		X	X	X		X				
12-X27121-000	X	X	X	X	X	X	X	X	X	X
12-X28021-005				X				X		

FIGURE 4: Dust Cover Application

This is a typical application of DETECT-A-FIRE units used as a release device to actuate a complete fire suppression system. In this application DETECT-A-FIRE units are mounted in a Dust Collector to sense an overheat condition and release a clean agent extinguishant.

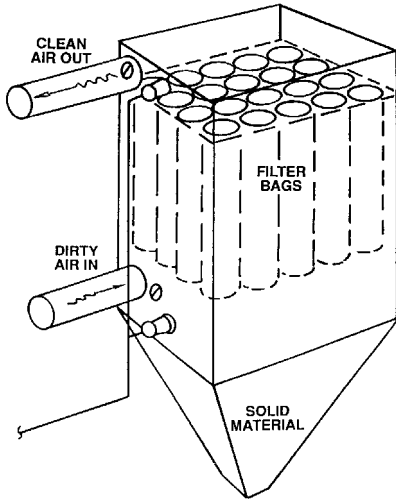

FIGURE 5: Typical ceiling installation of a horizontal DETECT-A-FIRE model. Here it is used in combination with a sprinkler system to detect overheat and actuate an alarm.



This chart shows three categories of fire detection devices and their relative response levels for reaction to three different rate-of-rise conditions. Statistics indicate that 97% of all fires fall within these categories.

RATE-OF-RISE			
TYPE OF DEVICE	UNDER 10 °F/MIN.	BETWEEN 10-40 °F/MIN	OVER 40 °F/MIN
Rate Compensated DETECT-A-FIRE Unit	FIRST	FIRST	SECOND but at selected protection level
Fixed Temperature	SECOND	SECOND	THIRD
Rate-of-Rise	Will not operate unless fixed temperature supplement at 165°F is provided, then it is THIRD in sequence	Will not operate unless fixed temperature supplement at 165°F is provided, then it is THIRD in sequence	FIRST but may be a false alarm

MODIFICATIONS

12-99202X-XXX, Extended lead wires, Series 12-X271XX and Series 12-X28XXX only.

12-992012-XXX, Fluorocarbon coating, Available on 27120-022, 27121-020, 28020-003, 28021-005 models only (500 °F max.).

AGENCY LISTINGS

Fenwal DETECT-A-FIRE units are UL and ULC listed and FM approved as fire detection thermostats (close on temperature rise) and as releasing devices (open on temperature rise).

AGENCY	FILE NUMBER	LOCATION
UL	S492	Ordinary
UL	E19310	Hazardous
ULC	CS341-E	Ordinary and Hazardous
FM	J.I. OV3HO.AE	Hazardous
FM	17302	Ordinary
UL	S2410	Ordinary (600 & 725 °F)
UL	E89599	Hazardous (600 & 725 °F)

HOW TO ORDER

1. Select the DETECT-A-FIRE model from specifications on pages 2 and 3.
2. Refer to temperature rating chart on page 2, select temperature setting required and add this number to base catalog number.

EXAMPLE: Vertical DETECT-A-FIRE set to close at 225°F.

12-X27121-000-225

Type _____ Temperature Setting _____



KIDDE-FENWAL INC.
400 MAIN STREET , ASHLAND, MA 01721
TEL: (508) 881-2000, FAX: (508) 881-6729
www.fenwalcontrols.com

A Kidde Company

These instructions do not purport to cover all the details or variations in the equipment described, nor do they provide for every possible contingency to be met in connection with installation, operation and maintenance. All specifications are subject to change without notice. Should further information be desired or should particular problems arise which are not covered sufficiently for the purchaser's purposes, the matter should be referred to KIDDE-FENWAL, Inc., Ashland, Massachusetts

© 2004 Kidde-Fenwal Inc. Printed in U.S.A. TAG 1.5M P/N 12.01.8 2/27/04